

STELTEC

Shanghai Steltec Energy Technology CO.,LTD
Address:Room J4986, Floor1, NO.185, Moyu Road , Anting Town,
Jiading District, Shanghai China
www.steltec-ess.com

V2.0-2023-11-18

STELTEC





Focus-H1 Operation Manual

This Manual introduces Focus-H1 from STELTEC.

Focus-H1 is a High-voltage Lithium-ion Phosphate Battery storage system. Please read this manual before you install the battery and follow the instruction carefully during the installation process. Any confusion, please contact us immediately for advice and clarification.

Catalogue

1	Technical Specification	1-2
2	Safety Information	
2.1	General Safety	3
2.2	Personal Safety	3
2.3	Electrical Safety	4-5
2.4	Transportation Safety	6
3	System Information	
3.1	Product introduction	7
3.2	Specification	7-8
3.2.1	Battery Module	7
3.2.2	High-voltage box	7
3.3	Port definitions	8-10
3.3.1	Connection Area	8
3.3.2	Start	8
3.3.3	Link Com Port	9
3.3.4	Link Power/Link in/Link out	9
3.3.5	LED Indicator Definition	10
4	Installation	
4.1	Tools	11
4.2	Checking deliverables	12-14
4.3	Installation	15-24
5	Commissioning Procedure	25
6	Maintenance	26

1. Technical Specication

Power module model	Number of power modules	Number of battery Modules	Battery System Capacity	Cell Technology	Battery System Voltage	Operating Voltage Range	Dimension (W*D*H)	Net Weight	Scalability	Installation	Depth of Discharge	Battery System Charge Current (recommendl)	Battery System Charge Current (Max)	Battery System Discharge Current (recommend)	Battery System Discharge Current (Max)	Display	Certificates		
Focus-H1	1	3	7.68kWh	Li-ion(LFP)	153.6V	129.6~168.48V	600*210*870(mm) 23.62*8.27*34.25(inch)	103.5kg (228.18 lb)	Max. Up to 10 systems in series operation	Floor stand	90%	40A	50A	40A	50A	The information of Battery, such as SOC, battery status	IEC62619 / IEC61000 / IEC62040 / CE / UN38.3		
		4	10.24kWh		204.8V	172.8~224.64V	600*210*1030(mm) 23.62*8.27*40.55(inch)	130kg (286.60 lb)										Communication Port	Protection Class
		5	12.8kWh		256V	216~280.8V	600*210*1190(mm) 23.62*8.27*46.85(inch)	156.5kg (345.02 lb)	RS485, CAN	IP65	0C~50C (32°F-122°F)	-20C~50C (-4°F-122°F)	5%-95%	2,000m (6,562ft.)	10 years	Natural convection			
		6	15.36kWh		307.2V	259.2~336.96V	600*210*1350(mm) 23.62*8.27*53.15 (inch)	183kg (403.45 lb)											
		7	17.92kWh		358.4V	302.4~393.12V	600*210*1510(mm) 23.62*8.27*59.45 (inch)	209.5kg (461.87 lb)											
		8	20.48kWh		409.6V	345.6~449.28V	600*210*1670(mm) 23.62*8.27*65.75(inch)	236kg (520.29 lb)											
		9	23.04kWh		460.8V	388.8~505.44V	600*210*1830(mm) 23.62*8.27*72.05(inch)	262.5kg (578.71 lb)											
		10	25.6kWh		512V	432~561.6V	600*210*1990(mm) 23.62*8.27*78.35 (inch)	289kg (637.14 lb)											
												STE-BSH-2560	Battery Cell Capacity	Configuration	Power module dimensions (W*D*H)	Battery Module dimensions (W*D*H)	Battery Base dimensions (W*D*H)	Battery Cover dimensions (W*D*H)	
													50Ah	1P16S	600*210*250 (mm) / 23.62*8.27*9.84 (inch)	600*210*160 (mm) / 23.62*8.27*6.30 (inch)	600*210*90 (mm) / 23.62*8.27*3.54 (inch)	600*210*50 (mm) / 23.62*8.27*1.96 (inch)	
											Battery module capacity	Battery Module Voltage	Power Module Weight	Battery Module Weight	Battery Base Weight	Battery Cover Weight			
											2.56kWh	51.2V	14kg (30.86lb)	27kg (59.52)	5kg (11.02lb)	2.5kg (5.51lb)			

2. Safety Information

2.1 General Safety

Please carefully read the manual safety precautions and observe all the safety instructions on the equipment and in this document.

The "DANGER", "WARNING", and "NOTICE" statements in this document do not cover all the safety instructions. They are only supplements to the safety instructions.

For user safety and utilization efficiency of this manual, a list of symbols is designed to alert people from danger. You must understand and comply with the emphasized information to avoid personal injury and property damage. Relative safety symbols have been listed below.

 Danger	DANGER indicates a hazardous situation which, if not avoided will result in serious injury and/or fire.
 Warning	WARNING indicates a hazardous situation which, if not avoided, will result in property loss and/or void the warranty.
 NOTICE	NOTICE indicates normal situation which, if not avoided, will result in damage to the battery.

NOTICE

Follow local laws and regulations when installing, operating, or maintaining the equipment. The safety instructions in this document are only supplements to local laws and regulations.

2.2 Personal Safety

Personal Requirements

People who plan to install or maintain battery equipment must be trained, understand all necessary safety precautions, and are able to correctly perform all operations.

Only qualified professionals or trained people are allowed to install, operate, and maintain the equipment.

▲ DANGER

- Do not place battery in an area accessible by children or pets.
- Do not touch the energized battery, the temperature of the battery enclosure may increase during operation.
- Do not touch the energized battery terminals.
- Do not stand on, lean on, or sit on the battery.

2.3 Electrical Safety

Symbols on Battery

There are some electrical symbols on battery relate to electrical safety. Please make sure you have fully understood them before installation.

	Electrical danger	Voltage exists when the battery is powered on. Only qualified engineers are allowed to operate.
	Earth connector	Earth connection.
+ -	DC positive and negative connectors	Identify positive and negative connectors of DC power source.
	CE mark	The product meets CE certification.
	WEEEtag	Batteries must not be disposed with general waste. It must be appropriately recycled in accordance with local regulations.
	Recycle	Batteries can be recycled, please refer to your local regulations regarding the correct disposal methods.

Electrical Safety

⚠ DANGER

- Before installation, ensure that the equipment is complete and intact. Otherwise, electric shocks or fire may occur.
- Do not connect or disconnect power cables when battery is power-on .
- Ensure the cables are terminated with the correct polarity. Failure to do so may result in electric arcs and cause may cause fire and/or personal injury.
- Do not connect the batteries in series with different products.
- Do not connect the battery directly to an AC power source.
- Do connect the battery directly to the PV modules or PV array.
- Do not connect batteries in parallel.
- Do not connect the battery to a faulty and/or a non Solplanet inverter.
- Do not create short circuits across the positive and negative terminals.
- Ensure the grid is cut off and the battery is powered off before maintenance.
- Ensure the earth cable is securely connected before operation.

⚠ WARNING

- Recharge battery in every six months if not in use.
- Recharge battery within 10 days after battery is fully discharged(SOC=0%).
- Ensure battery cable is installed correctly.
- When the battery is being installed or repaired, ensure the battery is powered off and and isolated. Using a multimeter check to ensure there is no voltage in the positive and negative terminals.

⚠ CAUTION

- Please use appropriately insulated tools for installation and maintenance.
- Please check the LED status when the battery is powered on.

- Please ensure the communication cable is connected correctly between the battery and the inverter.
- Please check for inverter alarms and the SOC reading once communication is established between the inverter and the battery.

Environment Safety

⚠ WARNING

- Ensure the battery is installed in a dry and well-ventilated location.
- The installation position must be away from direct sunlight and rain.
- The installation position must be far away from potential sources of fire..
- The installation position must be far away from all sources of water.
- Do not install the equipment in locations that contain flammable gases and/or flammable liquids.
- The operation and service life of the battery depends on the operating temperature. Operate the battery at a temperature equal to or better than the ambient temperature. The recommended operating temperature range is from 0°C to 30°C.

2.4 Transportation Safety

⚠ WARNING

- The products have passed UN38.3 certification.
- The products have MSDS documents available.
- The products belong to class 9 dangerous goods.
- **Please protect the packing case from the below situations:**
 - Being dampened by rains, snows, or falling into water.
 - Falling down or mechanical impact.
 - Being upside-down or tilted.

3. System Information

3.1 Product introduce

Focus-H1 is a high-voltage battery storage system based on lithium-iron phosphate technology. It is used to primarily store excess PV power that is generated by an inverter based PV system. **Focus--H1 is not suitable for supporting life-sustaining medical devices.**

3.2 Specification

3.2.1 Battery Module

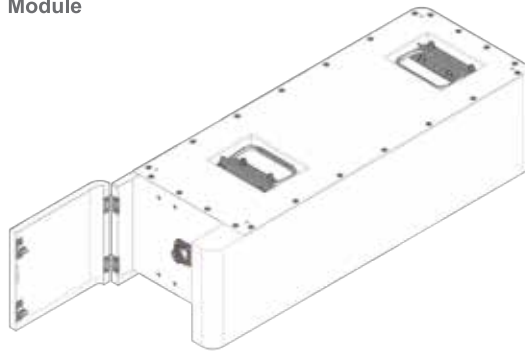

3.2.2 High-voltage box

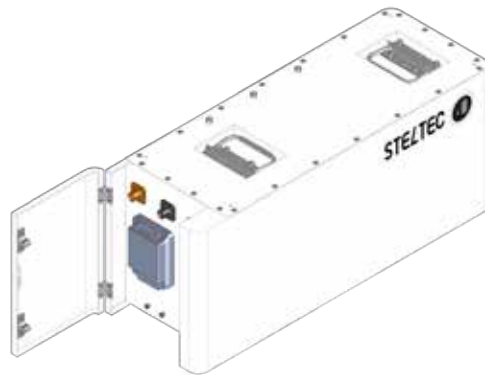

3.3 Port definitions

3.3.1 Connection Area

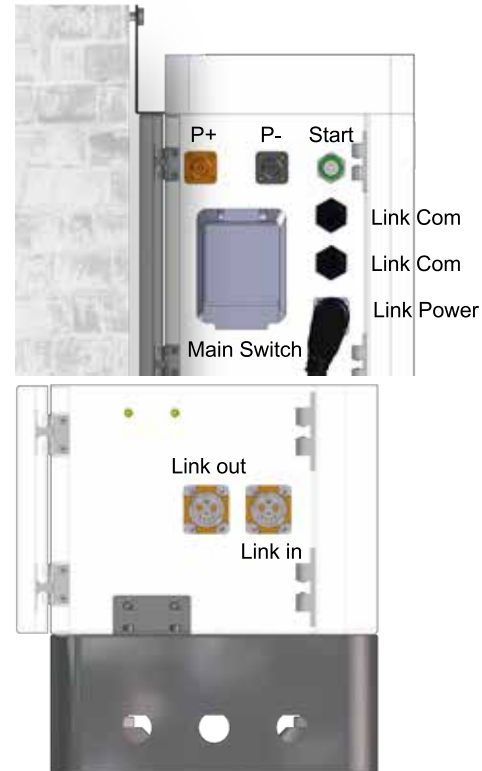

3.3.2 Start

(1) ON

For multiple Battery Modules in series , switch on the main switch then long press (more than 5 seconds) Start button of High-voltage box (which connect with inverter) , the normal LED on the front panel will illuminate. L1 to L5 shows battery SOC , L6 shows battery status .The high-voltage box which contains the BMS will automatically encode and assign an ID to each battery module. The battery can then operate.

(2) OFF

Press Start button of High-voltage box (Which connect with inverter) more than 5s , LED will flash in the front panel and then release the button , the master pack will shut down after all slave packs shut down (Sleep mode).

Tip:If the system does not work, keep the internal DC switch on the battery cluster closed.

3.3.3 Link Com Port

The Link Com Port is the interface between the high-voltage box and the inverter. The inverter retrieves the battery data such as SOC, DOD, charge current via this connection.

CAN / RS485/RS232 Communication Terminal (RJ45 port),

CAN/RS485 connect to inverter, follow CAN / RS485 protocol.

RS232 Communication follow RS232 protocol, for manufacturer or professional engineer to debug or service.

PIN	Definition
Pin 1	RS485-B (to PCS, reserved)
Pin 2	RS485-A (to PCS, reserved)
Pin 3	GND_2
Pin 4	CANH (to PCS)
Pin 5	CANL (to PCS)
Pin 6	RS232_TX
Pin 7	RS232_RX
Pin 8	RS232_GND

3.3.4 Link Power/Link in/Link out

Link Power/Link in/Link out are used for the communication between battery piles. The battery pack close to the inverter is the master, others are the slave pack.

3.3.5 LED Indicator Definition



flash 1 - every 0.25s on/3.75s off

flash 2- every 0.5s on/ 0.5s off



flash 3 - every 0.5s on / 1.5s off

LED Indicators Definitions

Status	Normal/Alarm/Protection	ALM ●	Battery Level IndicatorLED					Description
			●	●	●	●	●	
Shut down		OFF	OFF	OFF	OFF	OFF	OFF	ALL OFF
Standby	Normal	OFF	According to the battery level					Indicates Standby Module low voltage
	Alarm	Flash 3						
Charging	Normal	OFF	According to the battery level(The highest battery indicator LED Flash 2)					The highest battery level LED flashes (flash 2), and the ALM does not flash when the overcharge alarm occurs
	Alarm	Flash 3						
	Overcharge protection	OFF	Light	Light	Light	Light	Light	If there is no grid power, the indicator light turns to standby
	Protection	Light	OFF	OFF	OFF	OFF	OFF	Stop charging
Discharge	Normal	OFF	According to the battery level					
	Alarm	Flash 3						
	Under voltage protection	OFF	OFF	OFF	OFF	OFF	OFF	Stop discharging
	Protection	Light	OFF	OFF	OFF	OFF	OFF	Stop discharging
Fault		Light	OFF	OFF	OFF	OFF	OFF	Stop charging and discharging

4. Installation

4.1 Tools





Tools			
Installation	Rubber mallet	Star screwdriver	Hammer drill (10 mm)
	ESD gloves 	Safety goggles	Anti-dust respirator
	Safety shoes 	Level 	









4.2 Installation environment requirement

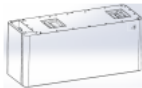



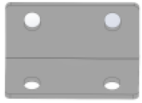

- Install the battery in the indoor environment.
- Place battery in secure location away from children and animals.
- Do not place the battery near any heat sources and avoid sparks.
- Do not expose the battery to moisture or liquids.
- Do not expose the battery to direct sunlight.
- Only mount battery on fire resistant building. Do not install batteries on flammable buildings.
- Battery is quite heavy, make sure the ground can meet the load bearing requirements, ground must be solid and hard enough and levelled well.

4.3 Checking deliverables

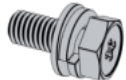
After unpacking the battery, check whether deliverables are intact and complete.

STE-BSH-2560 Packing list of battery box					
No.	Part No.	Part name/size	Quantity	Photo	Used for
1		Battery box 51.2V 50Ah RAL5014 Pigeon blue	1		
2	A02-006-00008A	Fixing plate V1.0_50*45_t=2mm_stainless steel	1		Fixing plate for multiple batteries
3	A06-001-00016A	Phillips hexagon screw with three combination bolt_M4*8mm_8.8 level 304 stainless steel	4		To fix the fixing plate
4	A06-001-00160A	Flat locating pin_φ 8*18.1_M5_Iron_Black	4		Used for positioning multiple packs
5	A05-001-00051A	V1.0_M23 Self-locking 8-core 2_1_5_Double-pin 90° with cord_length 80±5mm	1		Connection cable between multiple batteries
6	A10-012-00001A	2g moisture-proof desiccant	2		Moisture proof

STE-BC50 Packing list of high voltage box					
No.	Part no.	Specifications	Quantity	Photo	Used for
1		High voltage box	1		
2	A06-012-00004A	Foot 50*110*50mm	4		To let the base stand on
3	A02-004-00001A	The Base V1.0_600*210*90_t=2mm_SPCC_P antone 433C_Fine sand lines	1		To put at the bottom of the battery
4	A02-002-00005A	Top V1.0_600*210*50_t=1.5mm_SPCC_RAL9010_Fine sand grain	1		Install at the top of the battery
5	A02-005-00046A	L Wall Mount V1.0_215*62*42_t=2mm_SPCC_RA L9010_Fine sand grain	1		Used for attaching wall and battery
6	A02-006-00015A	50*25*2mm Stainless steel plate	1		
7	A03-006-00006A	SPM-100_Black waterproof clamping ring plug rod	4		Waterproof plug rod for top cover
8	A06-001-00160A	Flat locating pin_8*18.1_M5_stainless steels	4		Used for positioning multiple packs
9	A07-013-00002A	M23 Self-locking 8-core_2+1+5_4-hole flange socket_with gasket_12-foot short plug=M25 self-locking plug nut	1		Plug to conduct the circuit

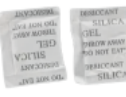
10	A06-001-00062A	Wall plug_M6*60mm_8.8level 304 stainless steel	3		To fix the wall hanging bracket
11	A06-001-00021A	Phillips hexagon screw with three combination bolt_M6*12mm_8.8 level 304 stainless steel	4		To lock the wall hanging bracket and grounding of the base
12	A06-001-00105A	Phillips slotted pan head screws_M5*20mm_8.8 level 304 stainless steel	4		To lock the top
13	A06-001-00016A	Phillips hexagon screw with three combination bolt_M4*8mm_8.8 level 304 stainless steel	4		To fix multiple packs
14	A05-001-00058A	Positive power cable V1.0_PSRP6XC25XA_1 red 8AWG soft silicone wire_length 2000mm_EV10-12	1		Battery positive power cable from high voltage box to inverter
15	A05-001-00059A	Negative power cable V1.0_PSRP6XA25XA_1 black 8AWG extra soft silicone wire_length 2000mm_EV10-12	1		Battery negative power cable from high voltage box to inverter
16	A05-002-00076A	V1.0_RNB1.25-6_1 yellow-green two-color grounding cable BVR2.5_length 2m_RNB1.25-6	1		Grounding cable
17	A05-006-00011A	Communication cable V1.0_RJ45 Crystal plug elbow waterproof_UL_CAT5E_FTP_24AW G_L Black-2000mm_RJ45 crystal plug	2		Communication cable from high voltage box to inverter
18	A10-012-00001A	2g moisture-proof desiccant	2		Moisture proof

4.4 Installation

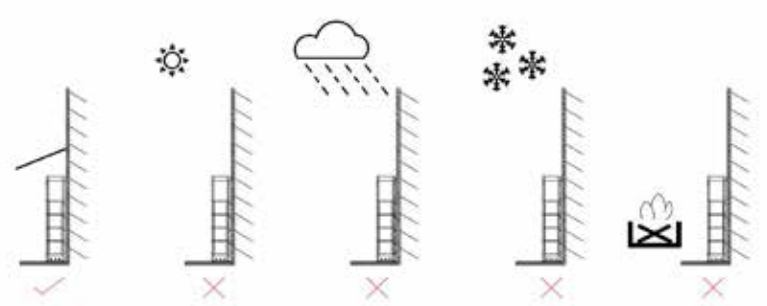

Step 1

Placed the base against the wall, the distance between the base and the wall is 30mm as followed.

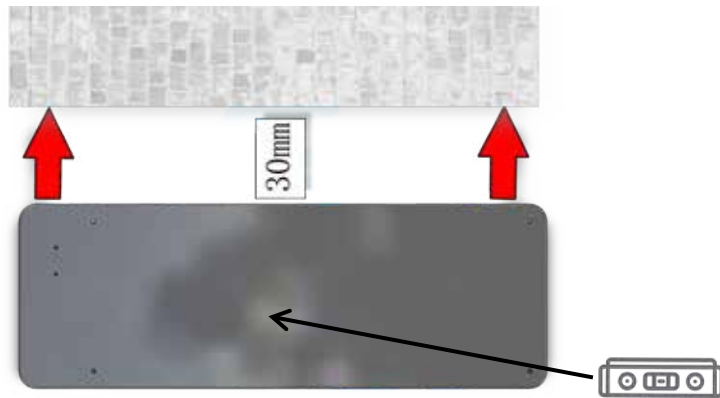

Note: Levelness of the base is less than 2mm.

Step 2

Screw the locating pin into the base and put the first battery pack on the base.

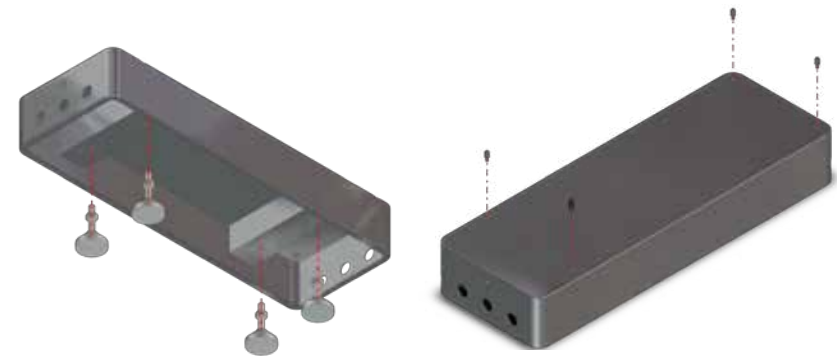

(2.1)

(2.2)

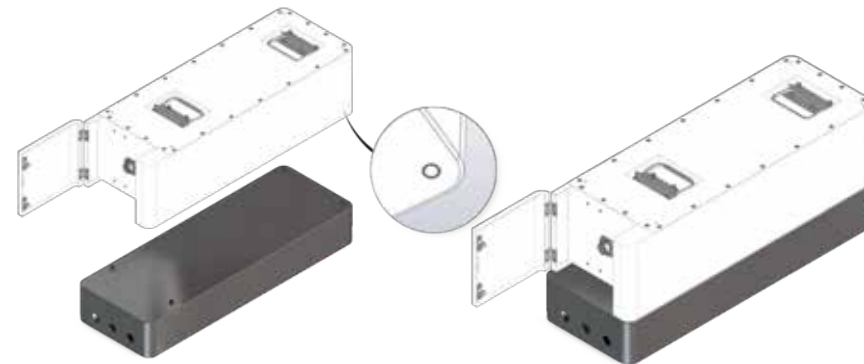

(2.3)

(2.4)

Step 3

Secure the battery module to the base with the stainless steel plate.

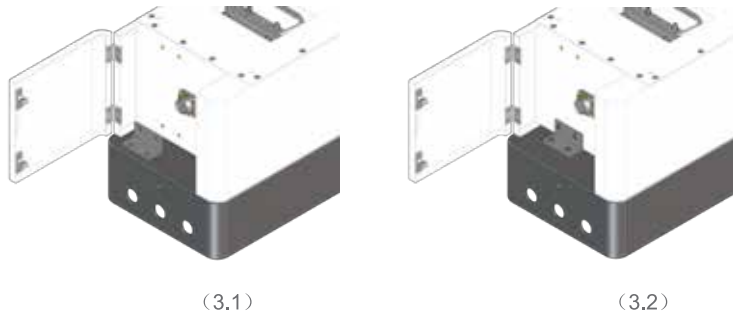

Step 4

Place the next battery module on top of the first battery module and secure the battery modules with the fixing plate. Repeat this step until all battery modules have been installed. Place the high-voltage box on top of the last module and secure it using the L-shape wall hanging bracket.

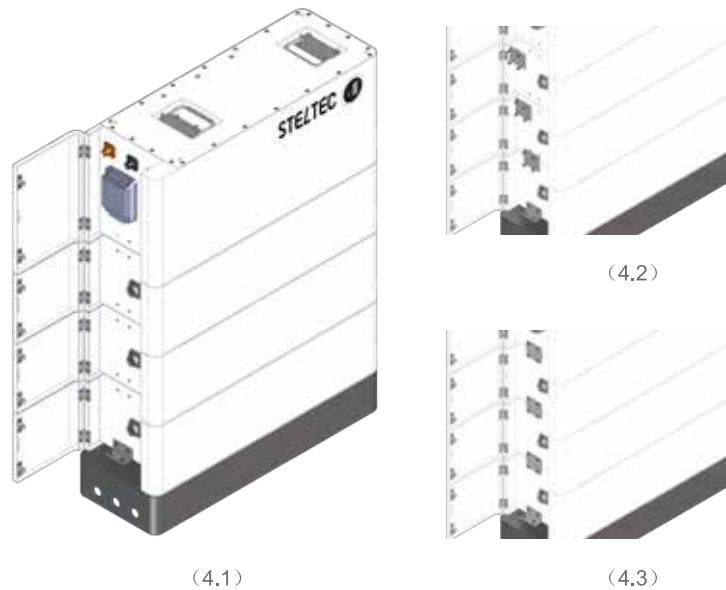

Step 5

Attached the L-shape wall hanging bracket onto the high voltage box as shown in the image.

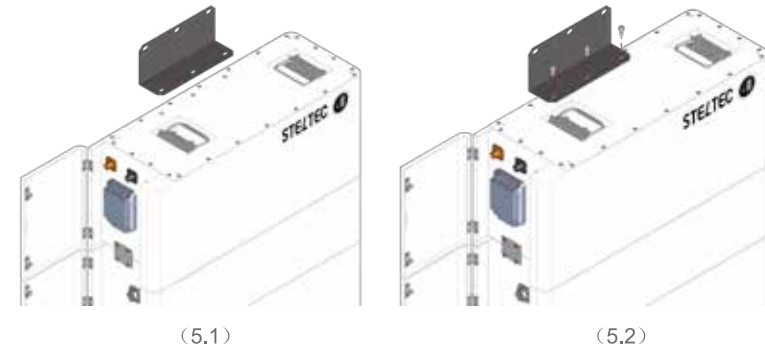

Step 6

Drill three holes of in the wall and insert three screw plugs. Insert three screws to secure the L-shape wall hanging bracket to the wall.

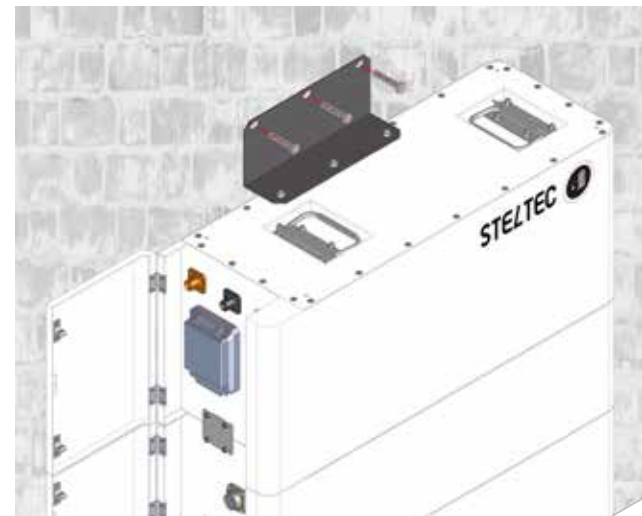

Step 7

Secure the top of the high voltage box with the provided screws.



(7.1)

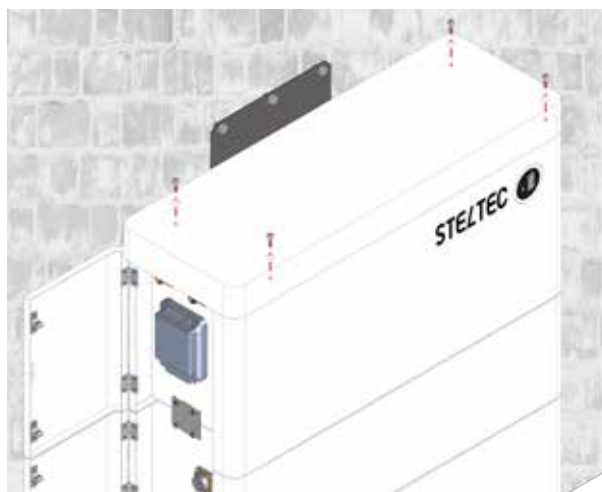

(7.2)

Step 8

Connect the small fixing plate between each modules as follows.

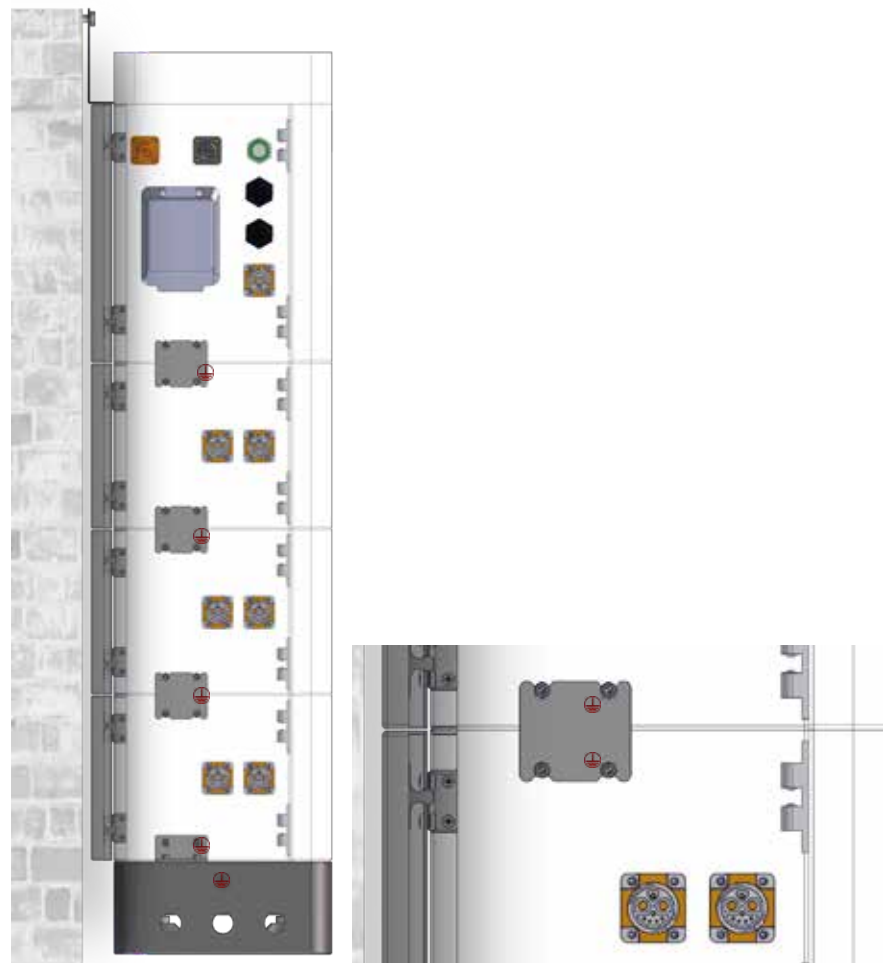

Step 9



Connect the power cables between the battery modules and the high-voltage box as shown.

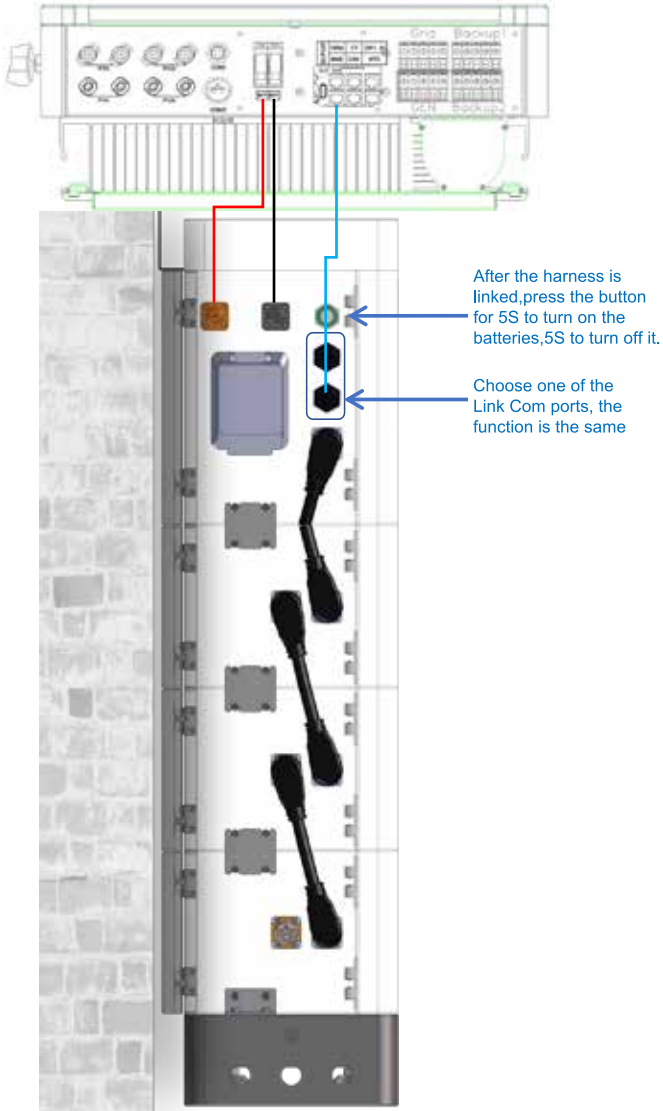

Connect the power through P+ and P- .

Connect the first High-voltage box Link Com Terminal to the inverter BMS port for communication between inverter and battery.



 Danger	<p>Ensure power cables are installed with the correct polarity. A dangerous situation may arise if the polarities are reversed.</p>
 Danger	<p>Do not create a short circuit between the positive and negative terminals of the battery. Ensure the polarity is correct during installation.</p>
 Warning	<p>Incorrect communication cable connection will cause the battery system to operate in unexpected ways which may lead to system failure.</p>

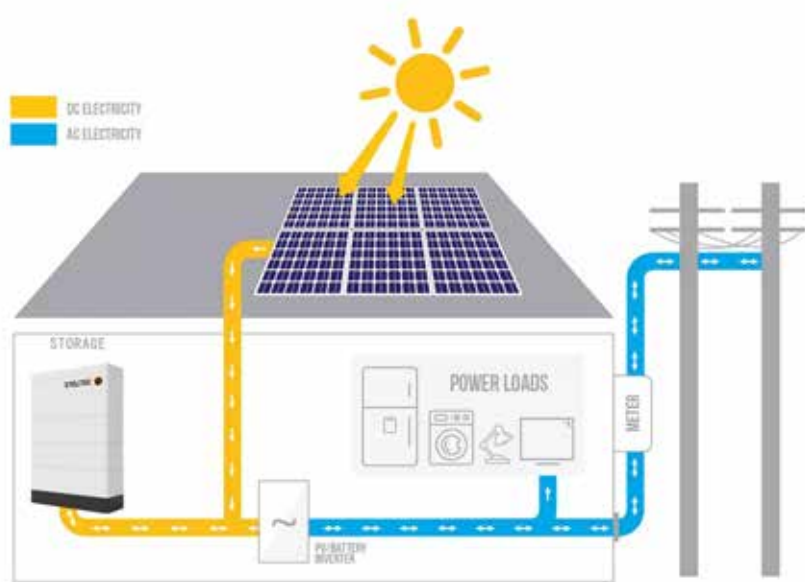

5. Commissioning Procedure

After all the cable (power and communication) connections are completed, please ensure the following:

- Ensure the DC switch on the inverter is OFF
- Ensure the AC switch that is connected to the grid and EPS output (if used) of the inverter is OFF
- Ensure the DC switch on the HV box is OFF

For commissioning we recommend the following steps:

- Turn the DC switch on the HV box ON
- Refer to section 2.3.2 Start for turning on the battery
- Wait until the HV box LED's on
- Wait until the inverter LED's on
- Turn the DC switch on the inverter ON
- Turn the AC switch that is connected to the grid and EPS output of the inverter ON
- Set-up the battery and the inverter using the App

6. Maintenance

● Recharge Requirements During Normal Storage

Battery should be stored in an environment with temperature range between -10°C ~ +45°C and maintained regularly according to following table with 0.5C(25A) current till 50% SOC after long storage time.

Storage Environment Temperature	Relative Humidity of Storage Environment	Storage Time	SOC
Below - 10°C	/	Prohibit	/
-10~25°C	5%~70%	≤ 12 months	SOC≥100%
25~45°C	5%~70%	≤ 12 months	SOC≥100%
Above 45°C	/	Prohibit	/

● Recharge Requirements When Over Discharged

Over discharged (90%DOD) battery should be recharged according to following table, otherwise over discharged battery will be damaged.

Storage Environment Temperature	Storage Time	Note
-10~25°C	≤ 15 days	Battery Pack disconnected from PCS
25~35°C	≤7 days	
-10~45°C	<12 hours	Battery Pack connected to PCS