

STELTEC

Shanghai Steltec Energy Technology CO.,LTD

Address:Room J4986, Floor1, NO.185, Moyu Road , Anting Town,

Jiading District, Shanghai China

www.steltec-ess.com

V2.0-2023-11-18

STELTEC





Focus-L1 Operation Manual

This Manual introduces Focus-L1 from STELTEC.

Focus-L1 is a Low-voltage Lithium-ion Phosphate Battery storage system. Please read this manual before you install the battery and follow the instruction carefully during the installation process. Any confusion, please contact STELTEC immediately for advice and clarification.

Catalogue

1	Technical Specification	1-2
2	Safety Information	
2.1	General Safety	3
2.2	Personal Safety	3-4
2.3	Electrical Safety	4-6
2.4	Transportation Safety	6
3	System Information	
3.1	Product introduction	7
3.2	BatteryModule	7
3.3	Port definitions	8-10
3.3.1	Connection Area	8
3.3.2	ON/OFF	8
3.3.3	Link Com Port	9
3.3.4	Link Power/Link in/Link out	9
3.3.5	LED Indicator Definition	10
4	Installation	
4.1	Tools	11
4.2	Checking deliverables	12-14
4.3	Installation	15-22
5	Commissioning Procedure	23
6	Maintenance	24

1. Technical Specication

Power module model	Number of battery Modules	Battery System Capacity	Cell Technology	Battery System Voltage	Operating Voltage Range	Dimension (W*D*H)	Net Weight
Focus-L1	1	5.22Wh	Li-ion(LFP)	51.2V	45.6-56.2V	515*200*490(mm) 20.28*7.87*19.29(inch)	56kg (123.46 lb)
	2	10.44kWh		51.2V	45.6-56.2V	515*200*840(mm) 20.28*7.87*33.07(inch)	102kg (224.87 lb)
	3	15.66kWh		51.2V	45.6-56.2V	515*200*1190(mm) 20.28*7.87*46.85(inch)	148kg (326.28 lb)
	4	20.88kWh		51.2V	45.6-56.2V	515*200*1540(mm) 20.28*7.87*60.63(inch)	194kg (427.7 lb)

Focus-L1	Battery Base dimensions (W*D*H)	Battery Cover dimensions (W*D*H)	Battery Base Weight	Battery Cover Weight
	515*200*90 (mm) 20.28*7.87*3.54 (inch)	515*200*50 (mm) 20.28*7.87*1.97 (inch)	5kg (11.02lb)	2.5kg (5.51lb)

Scalability	Installation	Depth of Discharge	Battery System Charge Current (recommend)	Battery System Charge Current (Max)	Battery System Discharge Current (recommend)	Battery System Discharge Current (Max)	Display	Certificates
Max 15 in parallel	Floor stand	90%	80A	100A	80A	100A	The information of Battery, such as SOC, battery status	IEC62619 / IEC61000 / IEC62040 / CE / UN38.3
Communication Port	Protection Class	Charging temperature	Discharge temperature	Humidity	Max. operating altitude	Warranty	Cooling	
RS232, RS485, CAN	IP54	0C~50C (32°F-122°F)	-20C~50C (-4°F-122°F)	5%-95%	2,000m (6,562ft.)	10 years	Natural convection	

STE-BSG 5220	Battery Cell Capacity	Configuration	Battery module dimensions (W*D*H)
	102Ah	1P16S	515*200*350(mm) 20.28*7.87*13.78 (inch)
Battery module capacity		Battery Module Voltage	Battery Module Weight
5.22kWh		51.2V	46kg (101.41 lb)

2. Safety Information

2.1 General Safety

Please carefully read the manual safety precautions and observe all the safety instructions on the equipment and in this document.

The "DANGER", "WARNING", and "NOTICE" statements in this document do not cover all the safety instructions. They are only supplements to the safety instructions.

For user safety and utilization efficiency of this manual, a list of symbols is designed to alert people from danger. You must understand and comply with the emphasized information to avoid personal injury and property damage. Relative safety symbols have been listed below.

 Danger	DANGER indicates a hazardous situation which, if not avoided will result in serious injury and/or fire.
 Warning	WARNING indicates a hazardous situation which, if not avoided, will result in property loss and/or void the warranty.
 NOTICE	NOTICE indicates normal situation which, if not avoided, will result in damage to the battery.

NOTICE

Follow local laws and regulations when installing, operating, or maintaining the equipment. The safety instructions in this document are only supplements to local laws and regulations.

2.2 Personal Safety

Personal Requirements

People who plan to install or maintain battery equipment must be trained, understand all necessary safety precautions, and are able to correctly perform all operations.

Only qualified professionals or trained people are allowed to install, operate, and maintain the equipment.

▲ DANGER

- Do not place battery in an area accessible by children or pets.
- Do not touch the energized battery, the temperature of the battery enclosure may increase during operation.
- Do not touch the energized battery terminals.
- Do not stand on, lean on, or sit on the battery.

2.3 Electrical Safety

Symbols on Battery

There are some electrical symbols on battery relate to electrical safety. Please make sure you have fully understood them before installation.

	Electrical danger	Voltage exists when the battery is powered on. Only qualified engineers are allowed to operate.
	Earth connector	Earth connection.
+ -	DC positive and negative connectors	Identify positive and negative connectors of DC power source.
	CE mark	The product meets CE certification.
	WEEEtag	Batteries must not be disposed with general waste. It must be appropriately recycled in accordance with local regulations.
	Recycle	Batteries can be recycled, please refer to your local regulations regarding the correct disposal methods.

Electrical Safety

⚠ DANGER

- Before installation, ensure that the equipment is intact. Otherwise, electric shocks or fire may occur.
- Do not connect or disconnect power cables when battery is power-on. Which may cause electric arcs and sparks more over fire or personal injury.
- Before connecting a power cable, check the positive or negative connectors are correct.
- Do not parallel connection with different batteries.
- Do not connect battery with AC directly.
- Do not connect battery with PV wiring directly.
- Do not connect batteries in series.
- Do not connect battery to faulty or unqualified inverter or charger.
- Do not create short circuits with the external connection.
- Make sure the grid is cut off and the battery is powered off before maintenance.
- Make sure the earth cable is connected correctly before operation.

⚠ WARNING

- Recharge battery in every six months if not in use.
- Recharge battery within 10 days after battery is fully discharged(SOC=0%).
- Ensure battery cable is installed correctly.
- When the battery is being installed or repaired, ensure the battery is powered off and and isolated. Using a multimeter check to ensure there is no voltage in the positive and negative terminals.

⚠ CAUTION

- Please use appropriately insulated tools for installation and maintenance.
- Please check the LED status when the battery is powered on.
- Please ensure the communication cable is connected correctly between the battery and the inverter.
- Please check for inverter alarms and the SOC reading once communication is established between the inverter and the battery.

Environment Safety

⚠ WARNING

- Ensure the battery is installed in a dry and well-ventilated location.
- The installation position must be away from direct sunlight and rain.
- The installation position must be far away from potential sources of fire..
- The installation position must be far away from all sources of water.
- Do not install the equipment in locations that contain flammable gases and/or flammable liquids.
- The operation and service life of the battery depends on the operating temperature. Operate the battery at a temperature equal to or better than the ambient temperature. The recommended operating temperature range is from 0°C to 30°C.

2.4 Transportation Safety

⚠ WARNING

- The products have passed UN38.3 certification.
- The products have MSDS documents available.
- The products belong to class 9 dangerous goods.
- **Please protect the packing case from the below situations:**
 - Being dampened by rains, snows, or falling into water.
 - Falling down or mechanical impact.
 - Being upside-down or tilted.

3. System Information

3.1 Product introduce

Focus-L1 is a low-voltage battery storage system based on lithium-iron phosphate technology. It is used to primarily store excess power that is generated by an inverter based PV system. **Focus--L1 is not suitable for supporting life-sustaining medical devices.**

Focus-L1 has built-in BMS (Battery Management System), which can manage and monitor cells information including voltage, current and temperature. Besides that, BMS can balance cells charging to extend cycle life. BMS has protection functions including over-discharge, over-charge, over-current and high/low temperature; the system can automatically manage charge state, discharge state and balance state.

Multiple Focus-L1 can be connected in parallel to expand capacity and power, 15 pcs can be connected in parallel at most.

Note: For multiple batteries in parallel, only the Master battery SOC LED will be on to show the whole system SOC level, slave battery SOC LEDs are off, but the Normal&Alarm LED will show normally.

3.2 Battery Module

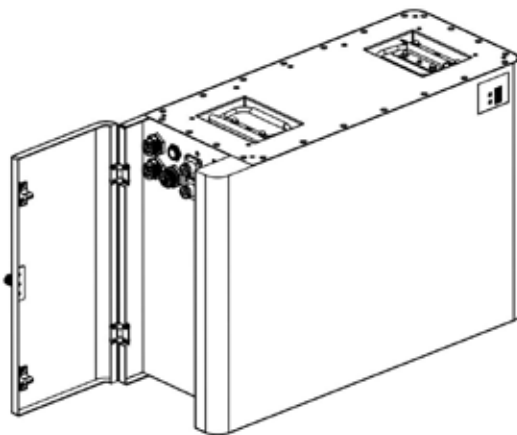

3.3 Port definitions

3.3.1 Connection Area

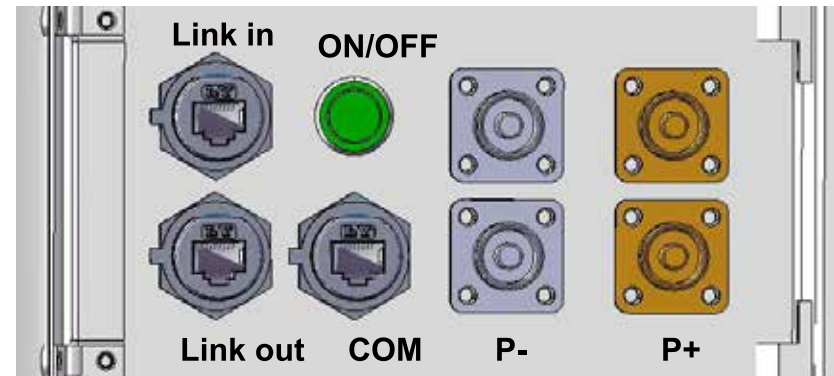

3.3.2 ON/OFF

1. ON

For single Battery Module, Long press (more than 3 seconds) ON/OFF button, Normal LED will be lighted in the front panel then battery will operate normally. L1 to L6 shows battery SOC, L7/L8 shows battery status.

For multiple Battery Modules in parallel, long press (more than 3 seconds) ON/OFF button of MASTER battery (Which connect with inverter), normal LED will be lighted, battery system will automatically encode and assign ID to each slave battery, then battery system will operate normally.

2 OFF

Press ON/OFF button of Master PACK (which connect with inverter) more than 3s, LED will flash in the front panel and then release the button, the master pack will shut down after all slave packs shut down (Sleep mode).

For single Battery Module, Long press (more than 3 seconds) ON/OFF button, LED will flash in the front panel and then release the button, the battery will shut down.

In the system with inverter, there is an air switch between inverter and battery system, normally the air switch keeps off-state if the system does not work.

3.3.3 Link Com Port

The Link Com Port is the interface between the high-voltage box and the inverter. The inverter retrieves the battery data such as SOC, DOD, charge current via this connection.

CAN / RS485/RS232 Communication Terminal (RJ45 port),

CAN/RS485 connect to inverter, follow CAN / RS485 protocol.

RS232 Communication follow RS232 protocol, for manufacturer or professional engineer to debug or service.

PIN	Definition
Pin 1	RS485-B (to PCS, reserved)
Pin 2	RS485-A (to PCS, reserved)
Pin 3	GND_2
Pin 4	CANH (to PCS)
Pin 5	CANL (to PCS)
Pin 6	RS232_TX
Pin 7	RS232_RX
Pin 8	RS232_GND

3.3.4 Link Power/Link in/Link out

Link Power/Link in/Link out are used for the communication between battery piles. The battery pack close to the inverter is the master, others are the slave pack.

3.3.5 LED Indicator Definition

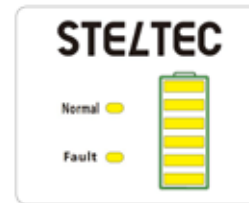

flash 1 - 0.25s on/3.75s off

flash 2 - 0.5s on/ 0.5s off



flash 3 - 0.5s on/ 1.5s off

LED Indicators Definitions

	Normal	Fault	Battery Level Indicator							Descriptions	
			L8	L7	L6	L5	L4	L3	L2		L1
Status	●	●	●	●	●	●	●	●	●	All OFF	
Shut down	OFF	OFF	OFF	OFF	OFF	OFF	OFF	OFF	OFF	All OFF	
Standby	Flash 1	OFF	According to the battery level							Indicates Standby	
Charging	Normal	Light	OFF	According to the battery level							The highest capacity indicator LED flashes(flash 2),others lighting
	Full Charged	Light	OFF	Light	Light	Light	Light	Light	Light	Turn to standby status when charger off	
	Protection	OFF	Light	OFF	OFF	OFF	OFF	OFF	OFF	Stop charging	
Discharge	Normal	Flash 3	OFF	According to the battery level							
	UVP	OFF	OFF	OFF	OFF	OFF	OFF	OFF	OFF	Stop charging	
	Protection	OFF	Light	OFF	OFF	OFF	OFF	OFF	OFF	Stop discharge	
Fault	OFF	Light	OFF	OFF	OFF	OFF	OFF	OFF	OFF	Stop charging and Discharge	

4. Installation

4.1 Tools









Tools			
Installation	Rubber mallet	Star screwdriver	Hammer drill (10 mm)
	ESD gloves 	Safety goggles	Anti-dust respirator
	Safety shoes 	Level 	

4.2 Installation environment requirement









- Install the battery in the indoor environment.
- Place battery in secure location away from children and animals.
- Do not place the battery near any heat sources and avoid sparks.
- Do not expose the battery to moisture or liquids.
- Do not expose the battery to direct sunlight.
- Only mount battery on fire resistant building. Do not install batteries on flammable buildings.
- Battery is quite heavy, make sure the ground can meet the load bearing requirements, ground must be solid and hard enough and levelled well.







4.3 Checking deliverables

After unpacking the battery, check whether deliverables are intact and complete.

Focus-L1 Battery box packing list					
NO.	Part No.	Part name/siz	Quantity	Photo	Used for
1	A02-006-00005A	Fixing plate between stacks V1.0_50*45_#2mm_stainless steel	1		To fix the stacks
2	/	51.2V102Ah Battery box	1		Battery box
3	A06-001-00016A	Crossed external hexagonal triple combination screws_M4*8mm_8.8 grade 304 stainless steel	4		To lock the fixing plate
4	A06-001-00160A	Flat locating pin_# 8*18.1_M65_inox_blackened	5		Used for positioning multiple packs
5	A05-001-00004A	Negative charging cable V1.0_PSRP60X230A_1 Black_4AWG Soft Silicone Cable_Wire Length 240mm_PSRP60X230A	1		Power cable -
6	A05-001-00005A	Positive charging cable V1.0_PSRP60X230A_1 Orange_4AWG Extra Soft Silicone Cable_Wire Length 240mm_PSRP60X230A	1		Power cable +
7	A05-006-00003A	Communication cable V1.0_RJ45 crystal plug double elbow waterproof_UL CAT5E FTD 34AWG black_L=290mm	1		Communication cable for parallel of multiple packs
8	A10-012-00001A	2g moisture-proof desiccant	2		Moisture-proof

Focus L1 System Accessories packing list

No.	Part No.	Part name/size	Quantity	Photo	Used for
1	A02-005-00016A	Support frame V1.0_215*62*62_t*2.0mm_SFCC_BAL9 003_fine sand	1		Used for attaching wall and battery
2	A02-004-00002A	The base V1.0_515*200*90_t*2.0mm_SFCC_Pan tong 433C_fine sand	1		To put at the bottom of the battery
3	A06-012-00004A	Foot 50*110*50mm	4		
4	A02-006-00015A	L type plate V1.0_50*25*25_t*0mm_stainless	1		
5	A02-002-00043A	The top V1.0_515*200*90_t*1.5mm_SFCC_BAL 9003_fine sand	1		Install at the top of the battery
6	A03-006-00006A	SPM-100_black clamp ring stick	4		
7	A06-001-00062A	Expansion screw_M6*60mm_8.8 level 304 stainless	3		To fix the support frame
8	A06-001-00022A	Cross screw with outer hexagon_M6*16mm_8.8 level 304 stainless	4		To fix the support frame
9	A06-001-00105A	Cross screw_M6*20mm_8.8 level 304 stainless	4		To fix the top

10	A06-001-00016A	Cross screw with outer hexagon_M6*8mm_8.8 level 304 stainless	4		To fix the base and L shape plate
11	A06-001-00160A	Flat locating pin_# 0*18.1_M6_iron_black	4		Used for positioning multiple packs
12	A06-002-00070A	Grounding cable V1.0_EMB1.25*6_1 pc yellow-green BV12.5_length 1.5m_EMB1.25*6	1		Used for the grounding
13	A06-001-00109A	Negative charging cable V1.0_PSRP6X25XA_1 pc black 4AWGsoft silicone cable_length 2000mm	1		
14	A06-001-00100A	Positive charging cable V1.0_PSRP6X25XA_1 pc orange cable 4AWG soft silicone cable_length 2000mm	1		
15	A06-006-00035A	V1.0_RJ45 crystal plug elbow waterproof_black super category 5 unshielded_custom wire sequence 4 to 8_5 to 7_cable length 800mm_RJ45 crystal plug	1		Communication cable between master pack and inverter(STELTEC or Senergy Inverter)
16	A06-006-00034A	V1.0_RJ45 crystal plug elbow waterproof_black super category 5 unshielded_custom wire sequence 4 to 4_5 to 5_cable length 800mm_RJ45 crystal plug	1		Communication cable between master pack and inverter(Deye, Growatt, Megarevo, Solis, Hoymiles, LUMPOWER inverter)
17	A07-006-00003A	Super Category 5 RJ45 shielded crystal head	4		To remake the communication cable's crystal head when necessary.

4.4 Installation

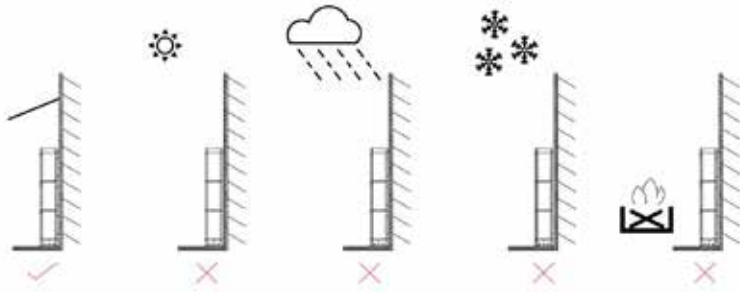

Step 1

Placed the base against the wall, the distance between the base and the wall is 30mm as followed.

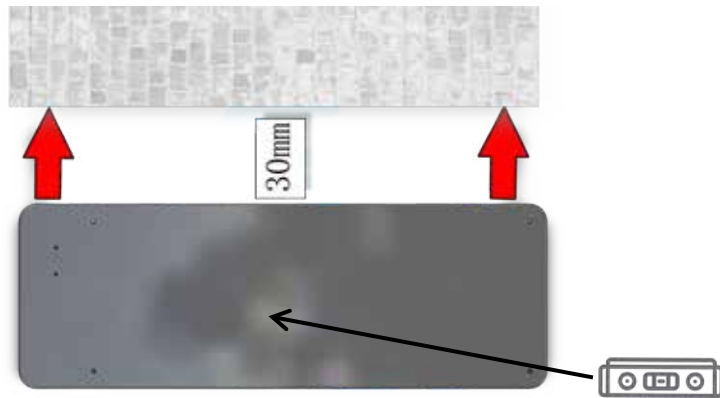

Note: Levelness of the base is less than 2mm.

Step 2

Screw the locating pin into the base and put the first battery pack on the base.

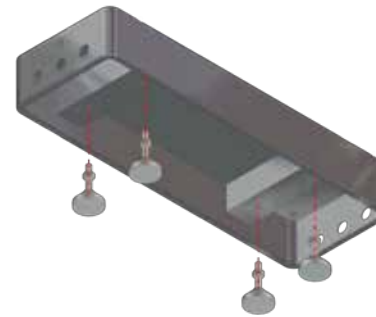

(2.1)

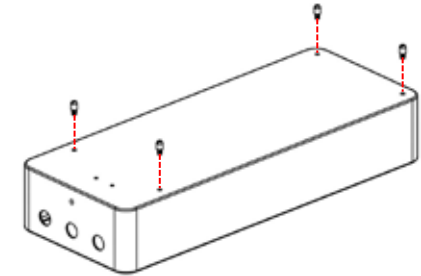

(2.2)

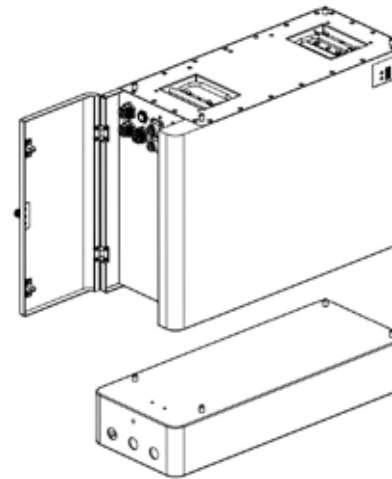

(2.3)

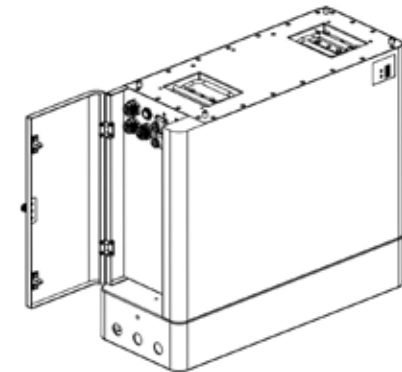

(2.4)

Step 3

Secure the battery module to the base with the L-shape plate.

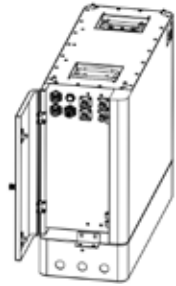

(3.1)

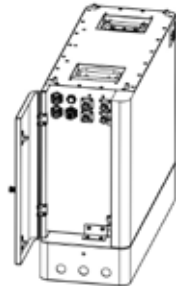

(3.2)

Step 4

Place the next battery module on top of the first battery module and secure the battery modules with the fixing plate. Repeat this step until all battery modules have been installed.

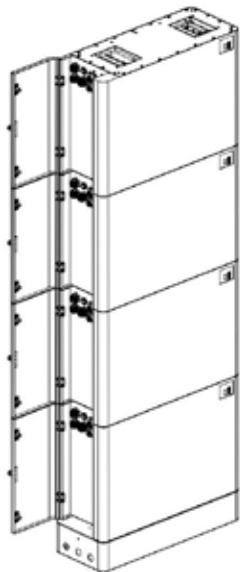

(4.1)

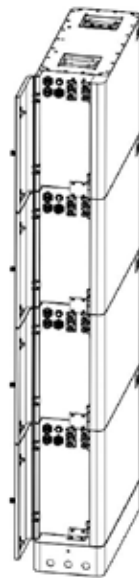

(4.2)

Step 5

Attached the L-shape support frame onto the battery as shown in the image.

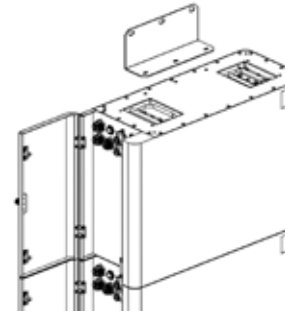

(5.1)

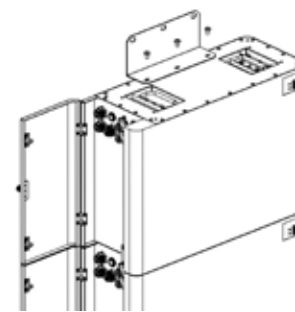

(5.2)

Step 6

Drill three holes of in the wall and insert three screw plugs.Insert three screws to secure the L-shape support frame to the wall.

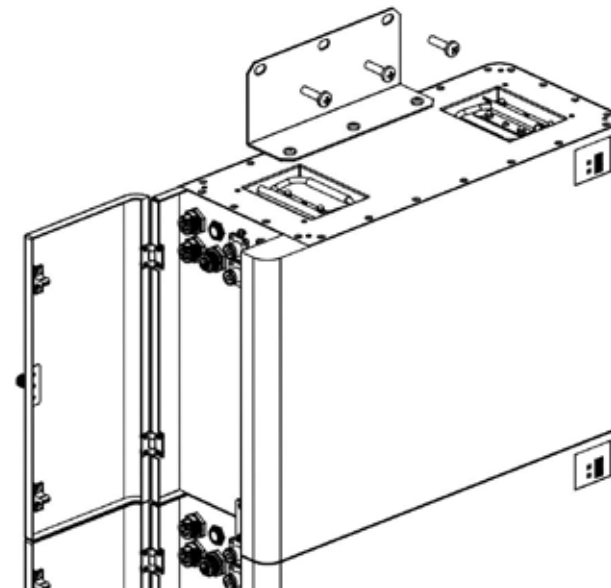

Step 7

Secure the top of the battery with the provided screws.

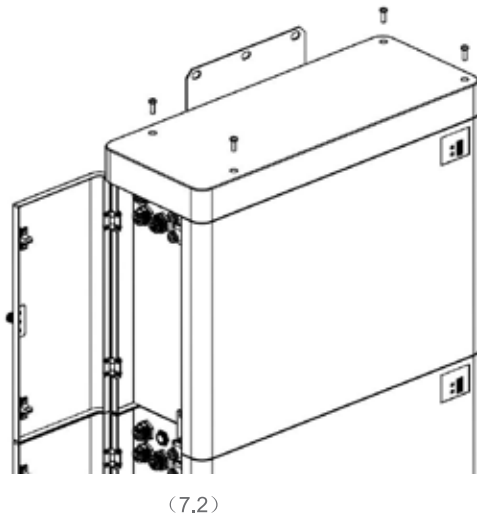
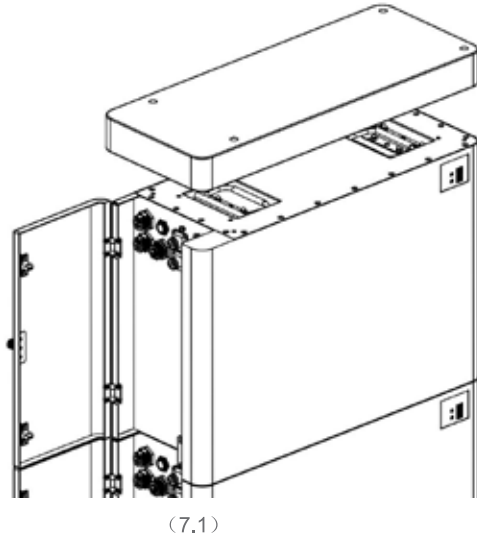

Step 8

Connect the small fixing plate between each modules as follows.

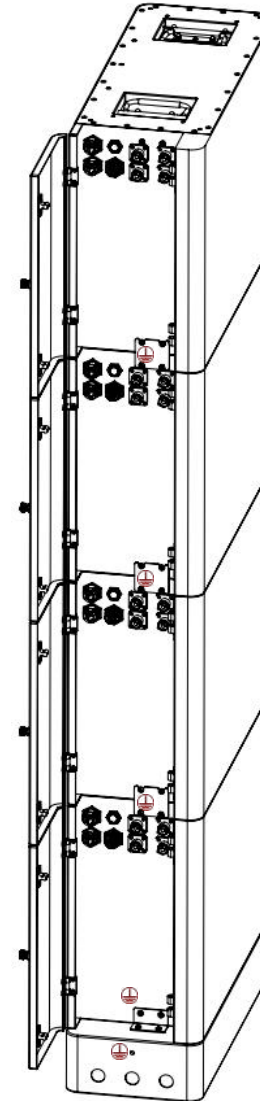

Step 9

Connect the power cables between the battery and the battery as shown.

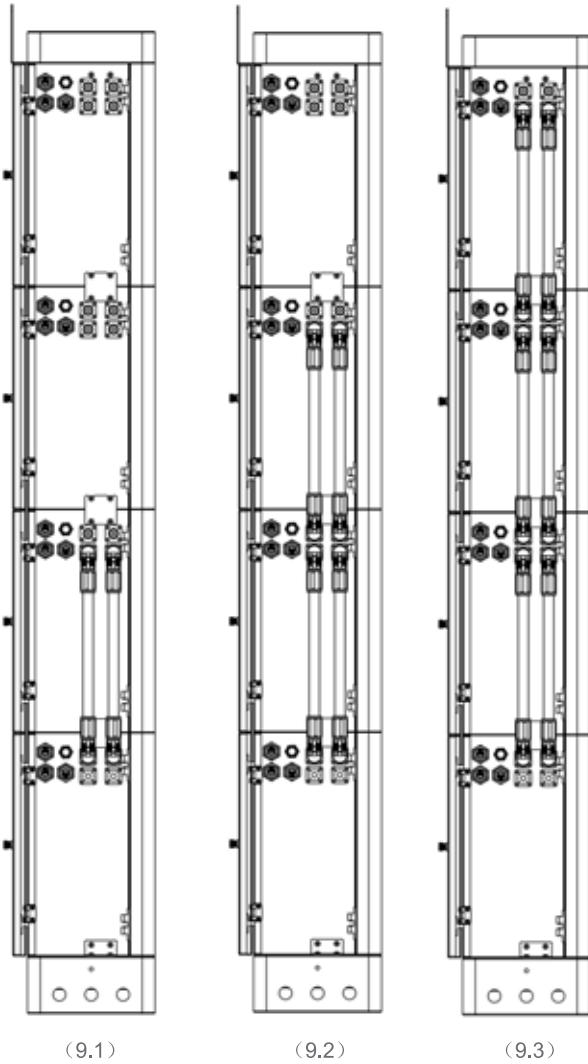

Connect the power through P+ and P- .

Connect the first battery pack COM Terminal to the inverter BMS port for communication between inverter and battery.

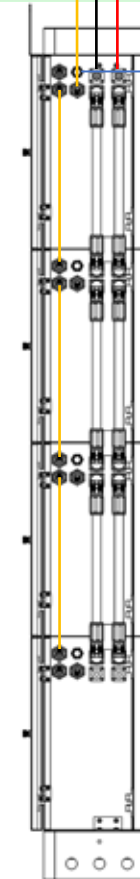
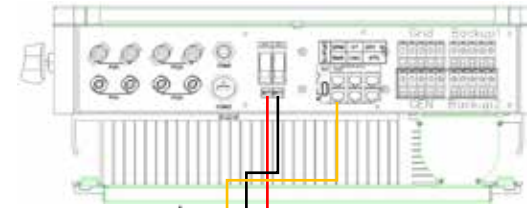

After the harness is linked,press the button for 3S to turn on the batteries,3S to turn off it.

Choose one of the Link Com ports, the function is the same

 Danger	<p>Ensure power cables are installed with the correct polarity. A dangerous situation may arise if the polarities are reversed.</p>
 Danger	<p>Do not create a short circuit between the positive and negative terminals of the battery. Ensure the polarity is correct during installation.</p>
 Warning	<p>Incorrect communication cable connection will cause the battery system to operate in unexpected ways which may lead to system failure.</p>

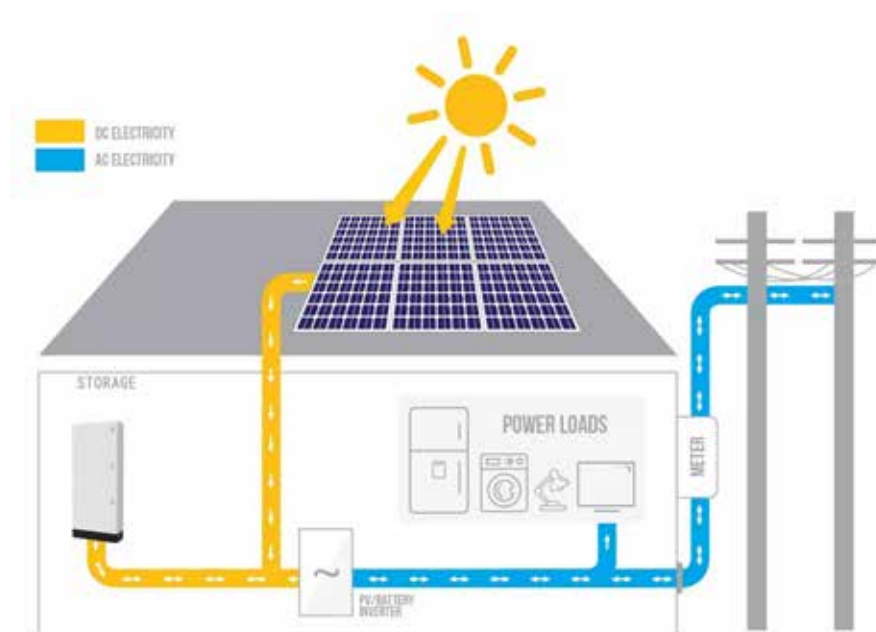

5. Commissioning Procedure

After all the cable (power and communication) connections are completed, please ensure the following:

- Ensure the DC switch on the inverter is OFF
- Ensure the AC switch that is connected to the grid and EPS output (if used) of the inverter is OFF
- Ensure the DC switch is OFF

For commissioning we recommend the following steps:

- Turn the DC switch ON
- Refer to section 2.3.2 Start for turning on the battery
- Wait until the LED's on
- Wait until the inverter LED's on
- Turn the DC switch on the inverter ON
- Set-up the battery and the inverter using the App
- Turn the AC switch that is connected to the grid and EPS output of the inverter ON
- Set-up the battery and the inverter using the App

6. Maintenance

● Recharge Requirements During Normal Storage

Battery should be stored in an environment with temperature range between $-10^{\circ}\text{C} \sim +45^{\circ}\text{C}$ and maintained regularly according to following table with 0.5C(50A) current till 50% SOC after long storage time.

Storage Environment Temperature	Relative Humidity of Storage Environment	Storage Time	SOC
Below -10°C	/	Prohibit	/
$-10\sim 25^{\circ}\text{C}$	5%~70%	≤ 12 months	SOC \geq 100%
$25\sim 45^{\circ}\text{C}$	5%~70%	≤ 12 months	SOC \geq 100%
Above 45°C	/	Prohibit	/

● Recharge Requirements When Over Discharged

Over discharged (90%DOD) battery should be recharged according to following table, otherwise over discharged battery will be damaged.

Storage Environment Temperature	Storage Time	Note
$-10\sim 25^{\circ}\text{C}$	≤ 15 days	Battery Pack disconnected from PCS
$25\sim 35^{\circ}\text{C}$	≤ 7 days	
$-10\sim 45^{\circ}\text{C}$	<12 hours	Battery Pack connected to PCS