

# STELTEC

Make your home  
Safe, stable and smart

## Energy Storage Battery LV Series

[www.steltec-ess.com](http://www.steltec-ess.com)  
[sales@steltec-ess.com](mailto:sales@steltec-ess.com)

Flex-II



**Flexible Investing**  
Expandable to 5.22-41.76kWh



**10 Years  
product warranty**



**Good-looking  
on the wall**



**Safe & Reliable**  
Lithium Battery (LFP)



**Intelligent Build in BMS**  
Monitored for 24\*7



**Easy Installation**  
Plug and Play

(Unit:mm)

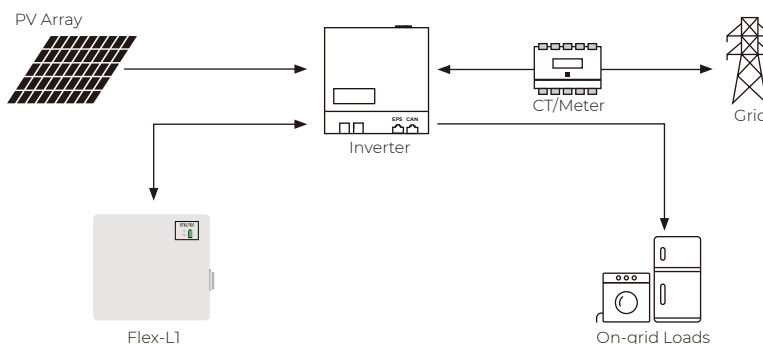
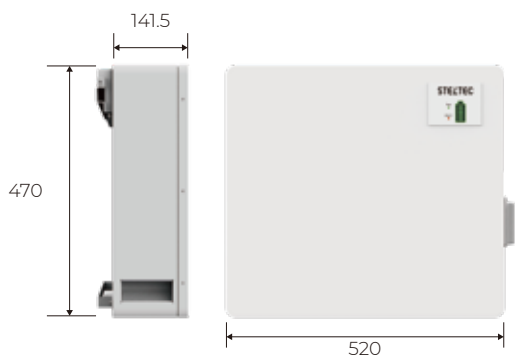

# STELTEC

Product type	Flex-L1
Technical specification	
Battery model	STE-BSW-5220
Battery System Capacity	5.12kWh
Cell Technology	Li-ion(LFP)
Battery Cell Capacity	100Ah
Configuration	1P16S
Nominal Voltage	51.2V
Operating Voltage Range	45.6~56.2V
Dimension (W*D*H)	520*141.5*470(mm) / 20.47*5.57*18.5(inch)
Net Weight	48kg (105.82 lb)
Scalability	Max. 15 systems in parallel operation
Installation	Wall mounted only
Depth of Discharge	90%
Battery System Charge Current (Normal)	80A
Battery System Charge Current (Max)	100A
Battery System Discharge Current (Normal)	80A
Battery System Discharge Current (Max)	100A
Cooling	Natural convection
Communication Port	RS232, RS485, CAN
Protection Class	IP54
Operating Temperature	0°C~50°C (32°F~122°F)
Shelf Temperature	-20°C~50°C (-4°F~122°F)
Humidity	5%-95%
Max. operating altitude	2,000m (6,562ft.)
Operation Life	10 years
Standard Compliance (more available upon request)	
Certificates	IEC62619 / IEC61000 / IEC62040 / CE / UN38.3