



## SKU: MTN-94631/SDM630MCT Modbus /Mbus /2T /MV THREE PHASE MULTI-FUNCTION ENERGY METER

- CT & PT operated
- Work with 3P4W / 3P3W / 1P2W
- 4 Module 72mm wide
- Multi-measurement:kWh,kVarh,W,Var,VA,PF,HZ,dmd,V,A,THD,etc.
- Bi-directional measurement
- 2 Pulse outputs
- RS485 Modbus or M-bus communication
- 2 Tariffs available(dual power source)



## Introduction

The SDM630M CT Series are three phase multifunction DIN rail meters. They can measure and display the characteristics of 1p2w,3p3w and 3p4w supplies, including voltage, current, power, active and reactive energy imported or exported. Energy is measured in terms of kWh, kVarh, Max. demand current can be measured over preset periods of up to 60 minutes. In order to measure energy, the unit requires voltage and current inputs to power the meter. The required current inputs are obtained via current transformers. This meter can be configurable to work with a wide range of CTs, giving the unit a wide range of operation. Build-in interface provides pulse and RS485 Modbus RTU or Mbus outputs. The configuration is password protected.

SDM630 CT Series have been assessed and certified as meeting the requirements of EU Directive 2014/32/EU. The instrument traceable number is 0120/SGS0142.



### SDM630MCT—5—J—2—4—1—C

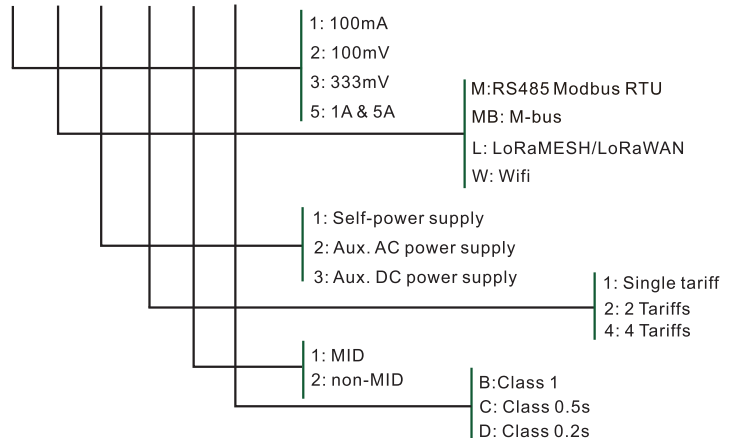

Specification	
Nominal voltage(Un)	3x230/400 V ac
Operational voltage	60%~120% of Un
Insulation capabilities	
- AC voltage withstand	4KV for 1 minute
- Impulse voltage withstand	6KV-1.2μS
Rated current (Ib)	5A CT or 333mV / 100mA CT input
Operational current range	0.4% Ib-I <sub>max</sub>
Over current withstand	20 I <sub>max</sub> for 0.01s
Operational frequency range	50 or 60Hz
Power consumption per phase	≤ 2W/10VA
Pulse output 1	Configurable
Pulse output 2	3200 imp/kWh
Display	LCD
Max reading	9999999.9 kWh/kVarh

Performance criteria	
Operating humidity	≤ 90%
Storage humidity	≤ 95%
Operating temperature	-25°C - +55°C
Storage temperature	-40°C - +70°C
Reference temperature	23°C± 2°C
International standard	IEC 62053-21/IEC 62053-22/ EN50470-1/3
Accuracy class	Class 1/Class 0.5S/Class B
Installation category	CAT III
Mechanical environment	M1
Electromagnetic environment	E2
Degree of pollution	2
Protection against penetration of dust and water	IP51 (indoor)
Insulating encased meter of protective class	II
Electrostatic discharges	8kV contact / 15kV air gap
Radiated & conducted emissions	EN 55022

Accuracy	
Voltage, Current	0.5%
Frequency	0.2% of mid-frequency
Power factor	1% of unity (0.01)
Active power, Apparent power	±1% of range maximum
Reactive power	±1% of range maximum
Reactive energy (Varh)	Class 2
Active energy (Wh)	Class 1/Class 0.5s

Modbus	
Bus type	RS485(semi-duplex)
Protocol	Modbus RTU
Baud rate	2400/4800/9600/19200/38400bps
Address range	1-247
Max. Bus loading	64pcs
Communication distance	1000M
Parity	EVEN/ODD/NONE
Data bit	8
Stop bit	1

M-bus	
Bus type	M-bus
Protocol	EN13757-3
Baud rate	600/1200/2400/4800/9600bps
Parity	NONE/EVEN/ODD
Stop bits	1 or 2
Primary Address	1 to 250
Secondary Address	00 00 00 01 to 99 99 99 99

### Wiring diagram

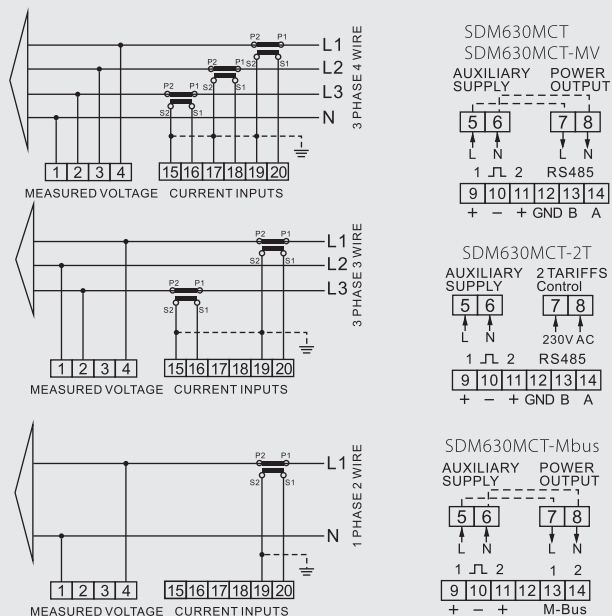

### Dimensions

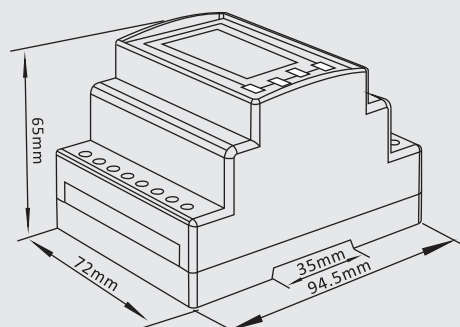

Height 94.5mm  
Width 72mm  
Depth 65mm